



CLARK

Prism 1.5 Bowl Overmount - Undermount

Suitable for item codes: PPR15B, PPR15BLH and PPR15BRH



Cut here for template



INSTALLATION INSTRUCTION FOR OVERMOUNT SINK

1. Inspect sink for damage and dimensional compatibility. Do not attempt to install a damaged sink.
2. Using the cut-out template mark the exact location of the required cut-out in the benchtop and draw a pencil line against the edge of the template.
3. Ensure that the tap location is suitable. Ensure that the supplied cut-out gives the desired fit.
4. Before commencing cutting, double check the marked cut-out dimensions. Cut out the bench top carefully following the inside edge of the marked line. An exact cut is required to obtain the best fit.
5. Position the sink in the cut out hole and align properly.
6. Check that the sink sealing tape will seal evenly around the edge of the hole.
7. Remove the sink and if required install the waste assemblies and the tap. It is suggested that silicone sealant be applied between the waste grate and the sink outlet hole.
8. Apply a continuous bead of silicone sealant on the lip of the sink and quickly place into position.
9. Position the sink in the cut out hole and align properly. The fixing clips are to be attached to the tabs on the sides of the bowl as shown in Figure A and B. Check that sealing tape will seal evenly around the edge of the hole.
10. Tighten the clips evenly using a low torque setting. See Figure C. Note: over tightening the clip may strip the thread.
11. Plumb up the tap and waste fittings.

INSTALLATION INSTRUCTION FOR UNDERMOUNT SINK

1. Inspect sink for damage and dimensional compatibility. Do not attempt to install a damaged sink.
2. Undermount sinks are designed for use with solid surface benchtops, examples as follows;
 - Natural Stone eg. Marble, Quartz etc
 - Engineered stone eg. CaesarStone, Silestone etc
 - Acrylic solid surfaces eg. Corian, Freestyle, Staron etc
 It is not recommended that undermount sinks be fitted to laminate benchtops. Contact your benchtop supplier to establish the type of material used. Your supplier should recommend a suitable adhesive and sealant for the specified material.
3. Using the cut-out template mark the exact location of the required cut-out in the benchtop. Ensure that the tap location is suitable. Ensure that the supplied cut-out gives the desired fit.
4. Using the appropriate tools and safety equipment cut the benchtop as marked out.
5. Mask the sink and the cut-out to avoid sealant/epoxy overspill onto finished surfaces.
6. Apply the recommended sealant at the edge of the join between sink and benchtop.
7. Apply the recommended adhesive as directed by adhesive supplier.
8. Position the sink in the desired final location and clamp to the benchtop.
9. Promptly remove excess sealant from benchtop and sink using a recommended clean up solvent suitable for your benchtop material and stainless steel.
10. When the installation has cured for the recommended period check that the seal is watertight and the attachment is secure.

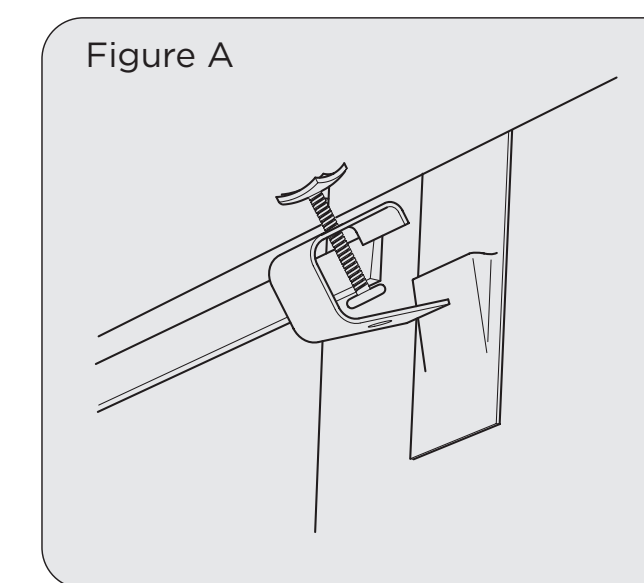

Figure A

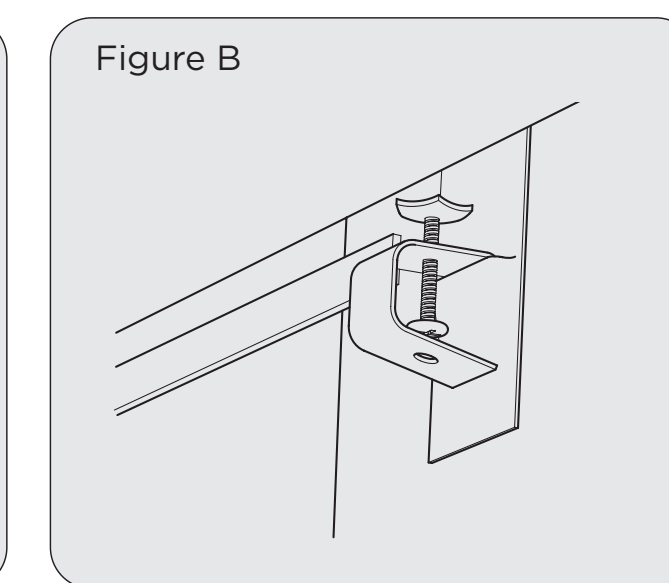

Figure B

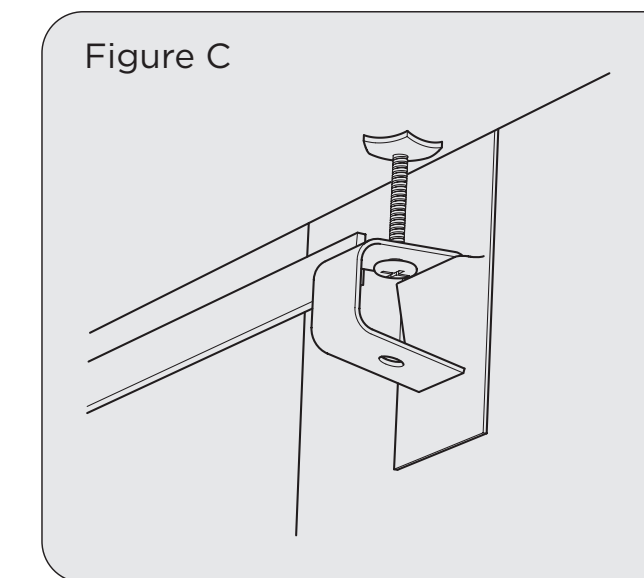

Figure C

NOTE: For thin benchtops special clips (A0167) are available.
CUTOUT TEMPLATE DIMENSIONS - 650 x 420mm
 To use this cutout template for benchtops, print 1:1 on a large format printer
 Corner radius 20mm
 For installation guide print to fit on paper size.



GWA
Bathrooms & Kitchens

Caroma Industries Limited
 ABN 35 000 189 499
 1 Melito Court, Prestons NSW 2170
 National Customer Call Centre
13 14 16
caroma.com.au



New Zealand
 National Customer Call Centre
09 279 2700
caroma.co.nz