

# Care 800 Cleanflush® Close Coupled 4.5/3 litre Cistern

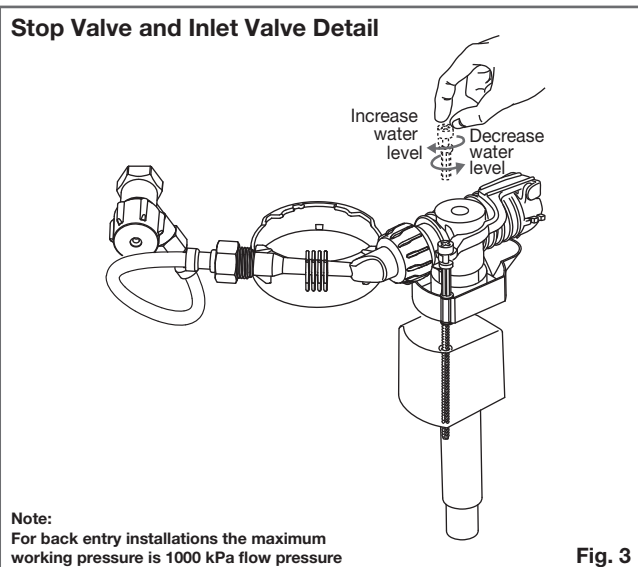
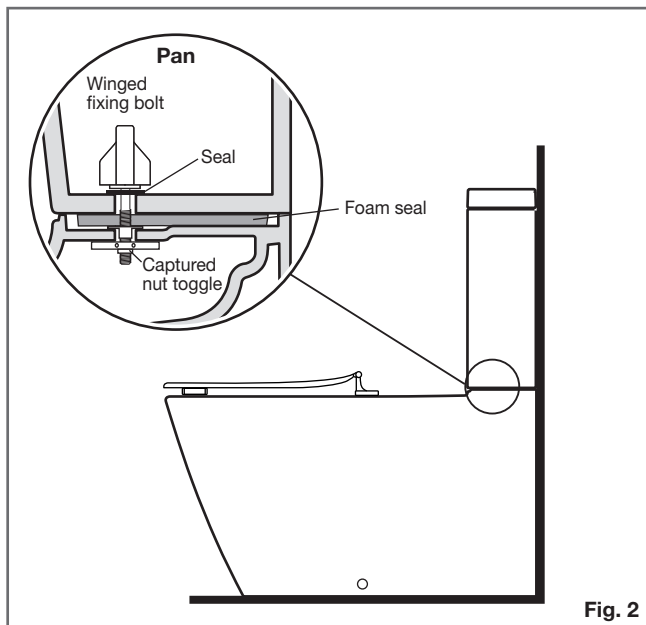
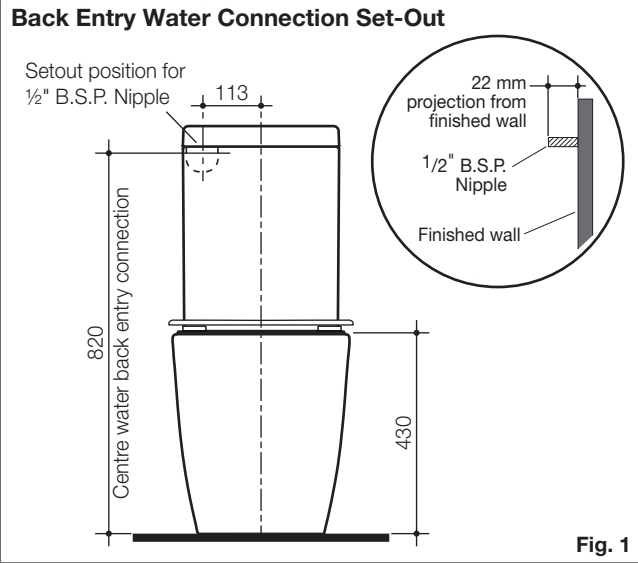

# PLUMBERS' INSTALLATION INSTRUCTIONS

**PLEASE READ CAREFULLY BEFORE INSTALLATION  
THESE CISTERN INSTRUCTIONS SUPERSEDE  
INSTRUCTIONS IN THE PAN CARTON**

## CISTERN FIXING PROCEDURE

**Note:** The cistern fixes directly to the pan with a robust base fixing system without the need for wall fixing.

## Back Entry Installation

- 1- Securely attach the self-adhesive foam seal around the outlet on the base of cistern. Remove inlet valve to gain access to the right hand cistern fixing hole.
- 2- Position cistern onto pan, and align the cistern fixing holes with the threaded fixing holes located in the cistern platform.
- 3- Ensure that the back inlet water connection nipple is aligned with the cut out in the back of the cistern. Fit the seals onto the winged fixing bolts.
- 4- Insert the winged fixing bolts through the cistern fixing holes into the threaded fixing holes located in the pan. Gradually tighten the left and right hand nuts by hand to firmly secure the cistern to pan, as detailed in **Fig.2**.
- 5- Fit cistern stop valve (supplied) to the 1/2" B.S.P. nipple in the wall using approved thread seal, in the downward angled position as detailed in **Fig. 3**. Connect one end of flexible hose to cistern stop valve.
 

**Note:** As specified in Australian Standard AS/NZS 3499, flexible hose assemblies shall not be submerged.
- 6- Refit the inlet valve into position.
- 7- Flush the lines before connecting the flexible hose to the stop tap and ensure the hose is not rubbing against the inside of the cistern.
- 8- Turn on water mains. Open cistern stop valve and check for leaks and operation of mechanisms and valves. Ensure there is no leakage from the cistern into the pan.
- 9- Adjust water level to the 4.5 litre water level mark inside the cistern by simply turning the float arm screw in a clockwise or anti-clockwise direction as detailed in **Fig. 3**.
- 10- Fit cistern lid to check push button operation to complete installation.



## IMPORTANT

TO ACHIEVE A SATISFACTORY 4.5/3L FLUSH PERFORMANCE AND A 4 STAR WATER EFFICIENCY RATING THE CISTERN MUST BE MATCHED WITH A COMPATIBLE CAROMA SMARTFLUSH 4.5/3L TOILET PAN.