

## Care 800 Cleanflush® 4.5/3 litre Back Inlet Pan

### PLUMBERS INSTALLATION INSTRUCTIONS For Vitreous China Caroma Care 800 Cleanflush® Back Inlet Pan PLEASE READ CAREFULLY BEFORE INSTALLATION

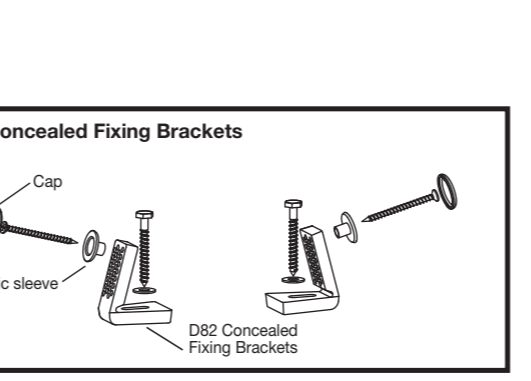
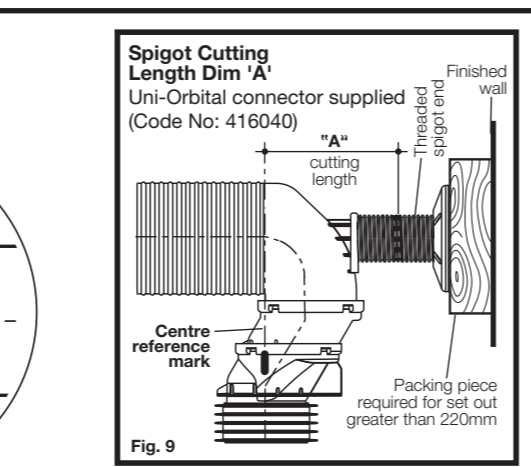
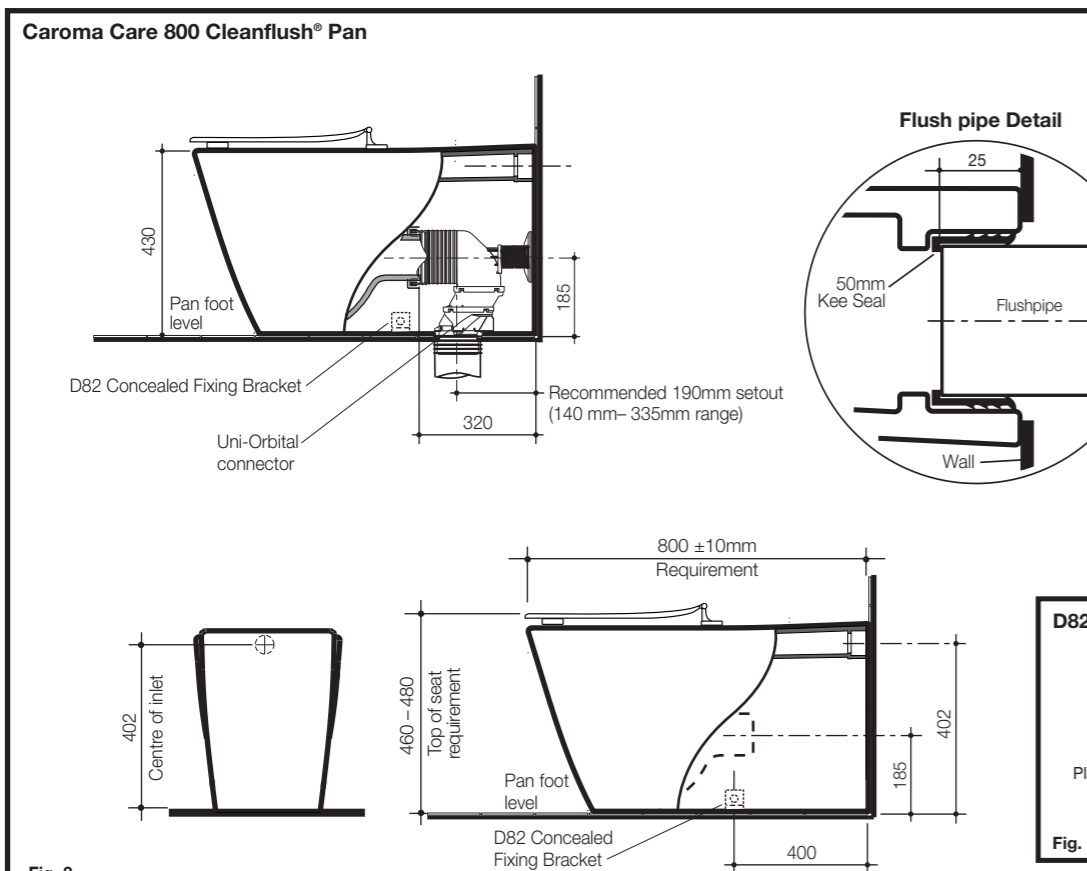
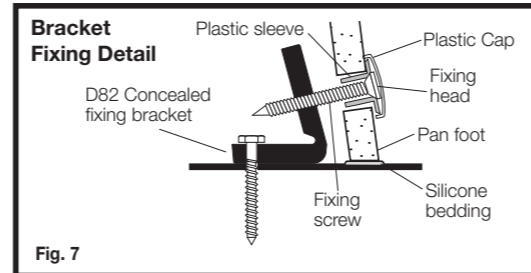
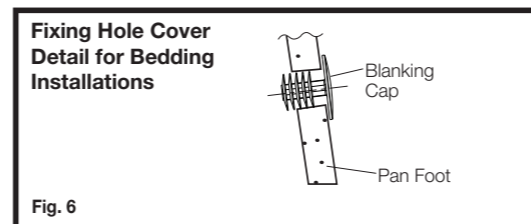
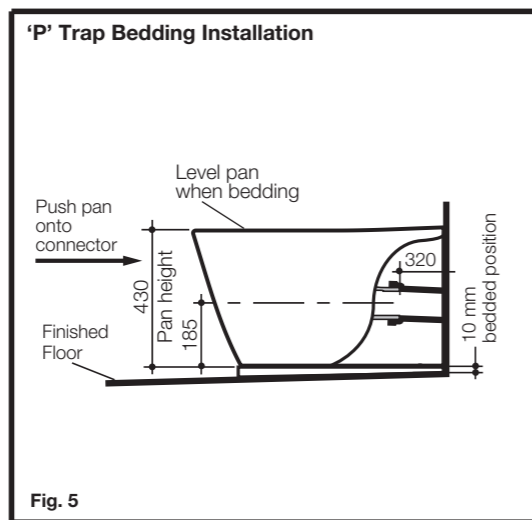
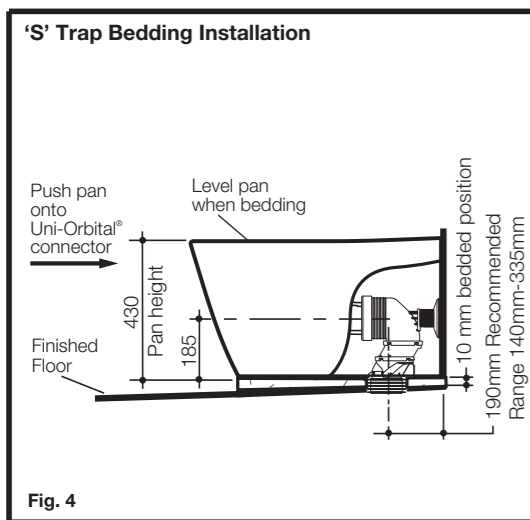
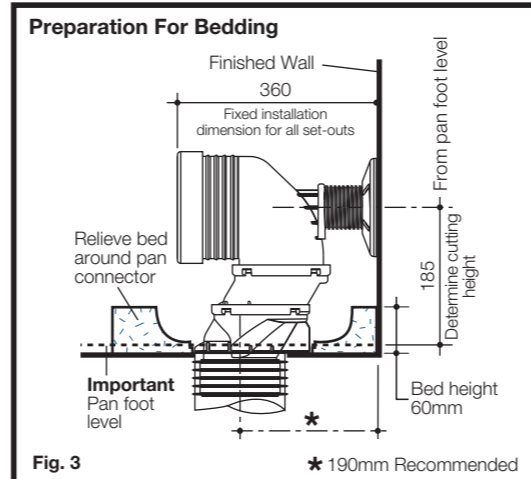
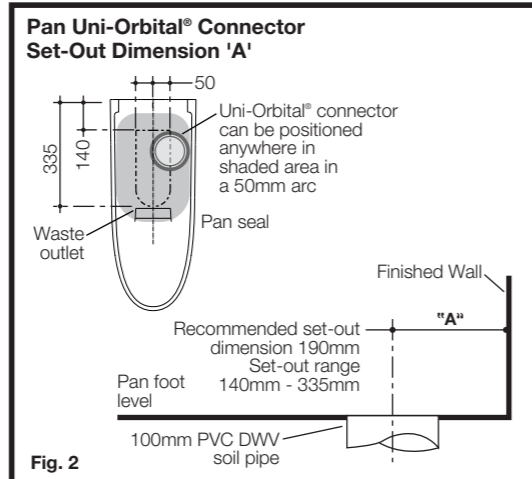
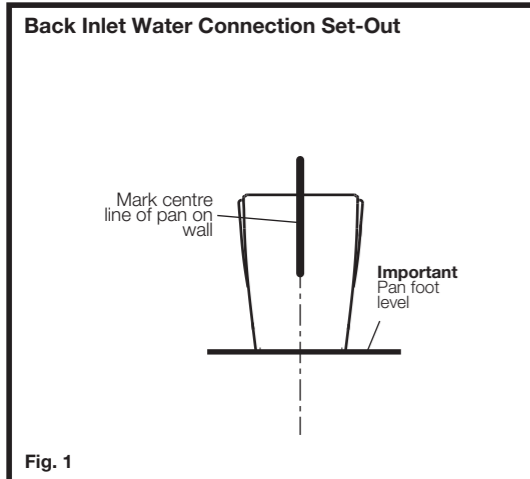

#### ROUGHING IN:

The Caroma Care 800 Cleanflush® pan has a projection of 800mm and has been developed to comply with the requirements of A.S. 1428-1 for wheelchair access. The pan is universal for both 'S' and 'P'-Trap installations. The set out range for the 'S' trap installation is from 140mm to 335mm and 50mm sideways adjustment with the Uni-Orbital® connector supplied (Code No: 416040). The recommended set out is 190mm from the wall as detailed in Fig. 2.

**For Care 800 Pan with Armrest Holes:** The Uni-Orbital® connector can only move forward and backwards, not sideways. The 50mm sideways adjustment, as detailed in Fig. 2, cannot be incorporated with the armrest bracket installed.

**Important:** Do not use offset connectors with the supplied Uni-Orbital® connector when installing this toilet pan. The use of offset connectors may cause the pan to siphon during the flush cycle.

#### 'S'- TRAP CONNECTOR FIXING PROCEDURE

Uni-Orbital® connector (supplied) 140mm-335mm set-out range with 50mm sideways adjustment.

If a setout range of 90mm-140mm is required, the optional Extended Uniconnector (Code No: 414260) can be used, this however will not allow for sideways adjustment, as detailed in Fig. 2.

1- Mark the centre line of the pan on finished wall, as detailed in Fig. 1. This is to be used as a guide when connecting the pan.

2- Determine set-out "A" of existing pan connector, as detailed in Fig. 2. Set-out range 140mm-335mm. Recommended set-out 190mm, as detailed in Fig. 4. For 'P' trap installation, see Fig. 5.

3- For installation of the Uni-Orbital® connector, reference must be made to the instructions supplied with the Uni-Orbital® connector. If the set-out is greater than 220mm a packing piece will be required from the Uni-Orbital® connector fixing nut to the finished wall, as detail in Fig. 9.

4- Prepare for pan fixing method (either bedding or bracket installation) as detailed below.

#### PAN FIXING PROCEDURE

##### Pan bedding:

1- Remove an area of tiles which are within the internal area covered by the foot of the pan to expose the sub floor and provide a bondage key for the bedding mixture.

2- Ensure that the bedding area is clean and free of building material.

3- Locate and Blanking Caps (supplied) into pan fixing holes, as detailed in Fig. 6.

4- Prepare bedding sand cement mixture 3:1 to depth of 60mm, as detailed in Fig. 3.  
**Note:** Do not fill the foot of the pan with bedding mix or include lime or fast drying cement into the mix, these may cause cracking in the foot of the pan.

5- Position and push pan into connector and flushpipe using the marked centre line on the wall as a guide and level pan into bedding mixture, so that the back of the foot of the pan is approximately 10mm above the finished floor, as detailed in Fig. 4 & 5. It is recommended that wedges are used to support the foot of the pan during the positioning.

##### Bracket fixing:

1- Position and push pan into connector and flushpipe using the marked centre line on the wall as a guide to ensure that all fittings locate correctly. Remove the pan.

2- Locate the D82 Concealed Fixing brackets (supplied) into position on centre line of pan 400mm from the finished wall and mark bracket fixing hole centres on finished floor.

3- Drill two holes in the marked positions on the floor. The hole diameter is dependent on the type of fixing system and floor finish.

4- Secure brackets to finished floor.

5- Ensure that the area around the floor is clean and free from building material.

6- Run a bead of acetic silicone sealant at a height of approximately 8mm fully around the foot of the pan which contacts the floor. Use Wedges around the foot base (if required) so that the **maximum height of silicone is not greater than 5mm on completion on bedding.**

7- Connect pan to connector and locate plastic fixing sleeve into holes in the pan. Insert screw into the bracket and tighten.

**IMPORTANT-DO NOT OVER TIGHTEN, AS THIS MAY CRACK THE PAN FOOT.**

Snap on plastic cap (supplied), as detailed in Fig. 7.

8- Provide support under the pan foot so that it is maintained in the levelled position while the silicone sealant sets. Remove any excess sealant to provide a neat joint between the pan and the floor. Allow at least 24 hours for the silicone sealant to set before use.



**IMPORTANT**  
TO ACHIEVE A SATISFACTORY 4.5/3L FLUSH PERFORMANCE AND A 4 STAR WATER EFFICIENCY RATING THIS TOILET PAN MUST BE MATCHED WITH A COMPATIBLE CAROMA SMARTFLUSH 4.5/3L CISTERN.

**IMPORTANT:** If the toilet pan you have purchased has captive nuts (toggle bolts) fitted in the seat fixing holes and the seat has rubber rawl plugs included for fixing, please disregard the rubber rawl plugs and fix the seat directly into the captive nuts (toggle bolts).

All measurements are subject to accepted manufacturing tolerances. To ensure accuracy please check actual product dimensions before drilling for installation. The manufacturer reserves the right to change specifications at any time without giving prior notification. This product should be installed by a qualified plumber. Local authority, Water Board, and Building Regulations may apply to the installation of this product, and you should consult the appropriate bodies on these requirements.