



EPIC - TOWER BASIN MIXER

WATER EFFICIENT TAPWARE

PLUMBERS INSTALLATION INSTRUCTIONS

Important Information

- * Not suitable for gravity feed systems.
- * Mixer is fitted with a flow regulator to achieve a flow rate in the range of 4.5-6.0 L/min. This low flow rate may not be suitable for connection to some Instantaneous Gas Water Heaters, some Tempering Valves, some Solar Water Heaters & some Thermostatic Mixing Valves. Check with the manufacturers of these products.
- * Isolating stop taps must be fitted to the hot & cold water supply connections. (Part No. 842018C - Mini cistern 1/4T)
- * All pipework must be thoroughly flushed prior to installation, as foreign materials may block the flow regulating device and reduce the flow of water.

Installation (Fig 1)

- 1) From fixing pack fit 'O' ring (11) into groove in base of mixer body (10). Screw studs (12) into underside of mixer body (10). **Optional:** Discard 'O' Ring (11) & fit base ring (13) together with 'O' Ring (14) into groove in base of mixer body (10).
- 2) **Flexible Tail Mixer Connections:** Apply suitable lubricant to 'O' rings (20). Fit flexible tail (19) (with red indication) into inlet fitting marked with a Red Dot inside mixer body (10). Hand tighten the tail, ensuring the 'O' ring (20) has fully entered the sealing bore to provide a watertight joint. Fit other flexible tail (with blue indication) into remaining fitting in a similar manner.
- 3) Insert the inlet connection end (17) of each flexible tail (19) through the hole in the deck. Place mixer over deck hole, fit gasket (15) and fixing plate (16) over studs (12) then screw on fixing nuts (18). Position mixer as required then tighten fixing nuts (18) using spanner (21) provided.
- 4) **Flexible Tail Inlet Connections:** Connect the flexible tails (19) to the hot and cold isolating stop taps, hand tighten the connecting nut (17) until rubber cone contacts the sealing face of the connection end, then tighten a further one turn to provide a watertight joint. **Important:** Flexible tails must not be kinked, twisted or in tension when installed. (Minimum Bend Radius:- 50mm) Do not install flexible tails where subject to ultra violet light.

IMPORTANT	
<u>Pressure & Temperature Requirements.</u>	
• Hot and cold water inlet pressures should be equal.	
• Static inlet pressure range : 150-1000 kPa	
New Regulation:- 500 kPa maximum static pressure at any outlet within a building. (Ref. AS/NZS 3500.1-2003, Clause 3.3.4)	
• Maximum hot water temperature : 80°C.	
<u>Deck Requirements</u>	
• Deck thickness : 40mm maximum	
• Tap body hole (in deck) : Ø34-36mm	

Replacing Cartridge

- 1) Turn off hot and cold water supplies.
- 2) Carefully remove plug (4) before using a 2.5mm allen key (3) to loosen grub screw (2) and remove handle (1). Remove cap (5) taking care not to damage the decorative finish. Unscrew nut (6) then lift out old cartridge (9).
- 3) Ensure inside face of mixer body (10) is clean. Check that seal (23) is in position in base of new cartridge (9). Fit new cartridge (9) into mixer body (10), taking care that two lugs on base of cartridge (9) fit into mating holes in mixer body (10).
- 4) Screw on nut (6). **Important:** Nut (6) should be tightened to a torque of 10 Nm.
- 5) Replace cap (5), tightening by hand. Fit handle (1) taking care that it is pushed fully down, then tighten grub screw (2). Replace plug (4) taking care not to damage the decorative finish.
- 6) Turn on water supplies and check operation.

Servicing the Flow Regulator

- If necessary, the flow regulator (22) can be accessed as follows:
- 1) Remove cartridge (9) as described in '**Replacing Cartridge**'. If required, flow regulator (22) can be extracted from mixer body (10) using a small hooked tool. Ensure flow regulator (22) is not damaged & is clean and free of blockages.
 - 2) When replacing, carefully insert flow regulator (22) into hole in mixer body (10) as shown ensuring it is bottomed. Replace cartridge as described in '**Replacing Cartridge**'.

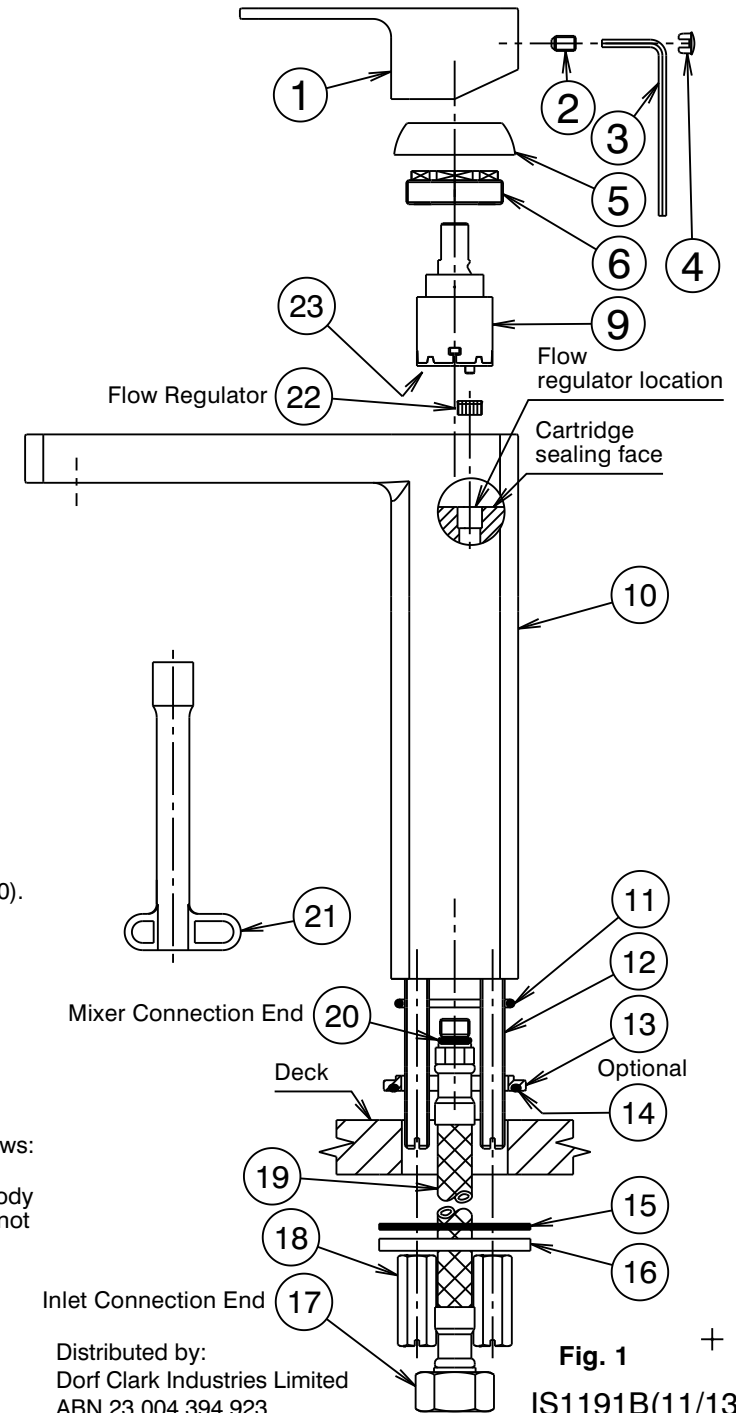

Distributed by:
Dorf Clark Industries Limited
ABN 23 004 394 923

Fig. 1
IS1191B(11/13)