



# JOVIAN - SINK MIXER WITH PULL DOWN SPRAY HEAD

## WATER EFFICIENT TAPWARE

(NOMINAL FLOW RATE = 7 L/min)

+

### PLUMBERS INSTALLATION INSTRUCTIONS

#### Important Information

- \* Not suitable for gravity feed systems.
- \* Mixer is fitted with a 7 L/min flow regulator.
- \* Isolating stop taps must be fitted to the hot & cold water supply connections. (Part No. 842018C - Mini cistern 1/4T)
- \* All pipework must be thoroughly flushed prior to installation, as foreign materials may block the flow regulating device and reduce the flow of water. Note: Aerator insert housing must be retightened to prevent removal by hand.

#### Installation (Fig. 1)

- 1) From fixing pack fit base seal (12) into groove in base of mixer (11). Screw studs (13) into underside of mixer body (11).
- 2) **Flexible Tail Mixer Connections:** Apply suitable lubricant to 'O' rings (20). Fit flexible tail (19) (with red indication) into hole marked with a Red Dot in underside of mixer body (11). Hand tighten the tail, ensuring the 'O' ring (20) has fully entered the sealing bore to provide a watertight joint. Fit other flexible tail (with blue indication) into remaining hole in a similar manner.
- 3) Insert the inlet connection end (18) of each flexible tail (19) through the hole in the deck. Place mixer over deck hole, fit gasket (15) and fixing plate (16) over studs (13) then screw on fixing nuts (17). Position mixer as required then tighten fixing nuts (17) using spanner (14) provided.
- 4) **Flexible Tail Inlet Connections:** Connect the flexible tails (19) to the hot and cold isolating stop taps, hand tighten the connecting nut (18) until rubber cone contacts the sealing face of the connection end, then tighten a further one turn to provide a watertight joint. **Important:** Flexible tails must not be kinked, twisted or in tension when installed. (Minimum Bend Radius:- 50mm) Do not install flexible tails where subject to ultra violet light.

IMPORTANT	
<b>Pressure &amp; Temperature Requirements.</b>	
<ul style="list-style-type: none"> <li>• Hot and cold water inlet pressures should be equal.</li> <li>• Static inlet pressure range : 150- 1000 kPa</li> <li>New Regulation:- 500 kPa maximum static pressure at any outlet within a building. (Ref. AS/NZS 3500.1- 2003, Clause 3.3.4)</li> <li>• Maximum hot water temperature : 80°C.</li> </ul>	
<b>Deck Requirements</b>	
<ul style="list-style-type: none"> <li>• Deck thickness : 40mm maximum</li> <li>• Tap body hole (in deck) : Ø34- 36mm</li> </ul>	

#### Servicing the Flow Regulator (Fig 2)

If necessary, the flow regulator (24) can be accessed as follows:

- 1) Remove screw (21) using 2mm allen key and carefully lift out swivel bracket (22) from mixer body (11). Remove retainer (23) from groove (25). If required, flow regulator (24) can be extracted from spigot on swivel bracket (22) using a small hooked tool. Ensure flow regulator (24) is clean and free of blockages.
- 2) When replacing, ensure flow regulator (24) is bottomed in bore in spigot of swivel bracket (22). Place retainer (23) in groove (25), then carefully insert the spigot of swivel spout into the mating hole in the mixer body (11), ensuring 'o' rings are well lubricated and that the threaded hole in the retainer (23) aligns with the side hole in the mixer body. Replace screw (21) and tighten.

#### Replacing Cartridge (Fig. 1)

- 1) Turn off hot and cold water supplies.
- 2) Carefully remove plug (3) before using a 2.5mm allen key (4) to loosen grub screw (2) and remove handle (1). Remove cap (5) taking care not to damage the decorative finish. Unscrew nut (6) then lift out old cartridge (9).
- 3) Ensure inside face of mixer body (11) is clean. Check that seals (10) are in position in base of new cartridge (9). Fit new cartridge (9) into mixer body (11), taking care that two lugs on base of cartridge (9) fit into mating holes in mixer body (11).
- 4) Screw on nut (6). **Important:** Nut (6) should be tightened to a torque of 10 Nm.
- 5) Replace cap (5), tightening by hand. Fit handle (1) taking care that it is pushed fully down, then tighten grub screw (2). Replace plug (3) taking care not to damage the decorative finish.
- 6) Turn on water supplies and check operation.

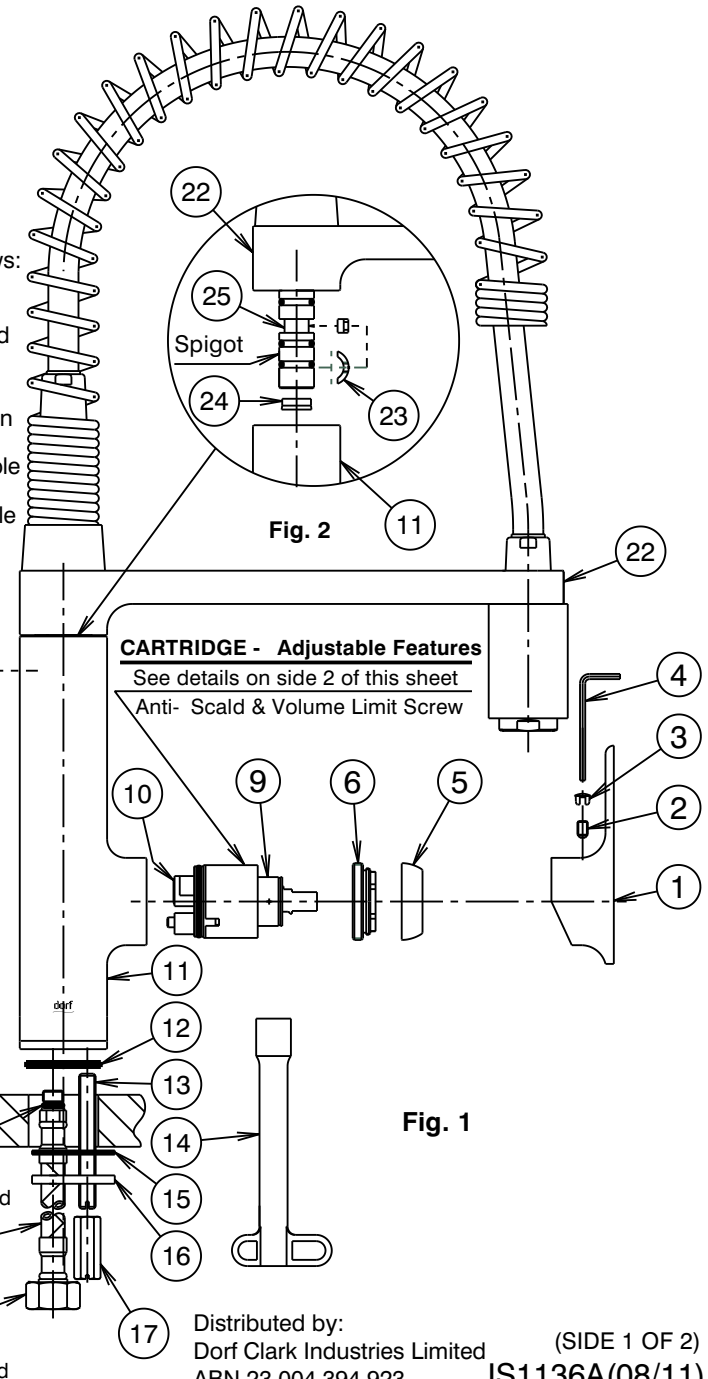



# JOVIAN - SINK MIXER WITH PULL DOWN SPRAY HEAD

+

## WATER EFFICIENT TAPWARE (NOMINAL FLOW RATE = 7 L/min)

### PLUMBERS ADJUSTMENT INSTRUCTIONS

#### Adjusting the HOT LIMIT RING (ANTI- SCALD STOP RING)

The cartridge fitted in this mixer has been factory pre- set to deliver the maximum available hot water temperature. To use the ANTI- SCALD feature adjust the cartridge as follows:-

Carefully remove plug (2). Using 2.5mm allen key (3) loosen screw (4) and remove handle (1). Unscrew cap (5) taking care not to damage the decorative finish. (See details on side 1 of this sheet.)

To remove the Hot Limit Ring (7) from the cartridge (9), use a small thin flat bladed screwdriver and carefully lever in an upwards direction.

Rotate the Ring (7) in a clockwise direction then refit the Ring (7) onto the cartridge (9).

**Note:-** Start by rotating the Ring (7) in small increments, then check the hot water temperature with the mixer handle in the fully open maximum hot water position. The Ring (7) can be removed & repositioned until the desired maximum hot water temperature is achieved.

Ensure the Ring (7) is pushed fully down onto the cartridge (9), then replace cap (5), tightening by hand. Fit handle (1), taking care that it is pushed fully down, tighten screw (4) and replace plug (2).

#### Adjusting the WATER VOLUME LIMIT SCREW

The cartridge fitted in this mixer has been factory pre- set to deliver the maximum flow of water when the mixer handle is in the fully open position.

**Important Note:-** This Sink Mixer is already fitted with a 7.0 L/min flow regulator. Lower flow rates may not be suitable for connection to some Instantaneous Gas Water Heaters, some Tempering Valves, some Solar Water Heaters & some Thermostatic Mixing Valves. Check with the manufacturers of these products. However, the flow of water may be reduced further by adjusting the cartridge as follows:-

Carefully remove plug (2). Using 2.5mm allen key (3) loosen screw (4) and remove handle (1). Unscrew cap (5) taking care not to damage the decorative finish. (See details on side 1 of this sheet.)

Using a small thin flat bladed screwdriver, adjust screw (8) in an anti- clockwise direction.

**Note:-** Start by rotating the Screw (8) in small amounts then check the flow of water with the mixer handle in the fully open position. Readjust the screw until the desired water flow is achieved.

Replace cap (5), tightening by hand. Fit handle (1), taking care that it is pushed fully down, tighten screw (4) and replace plug (2).

+

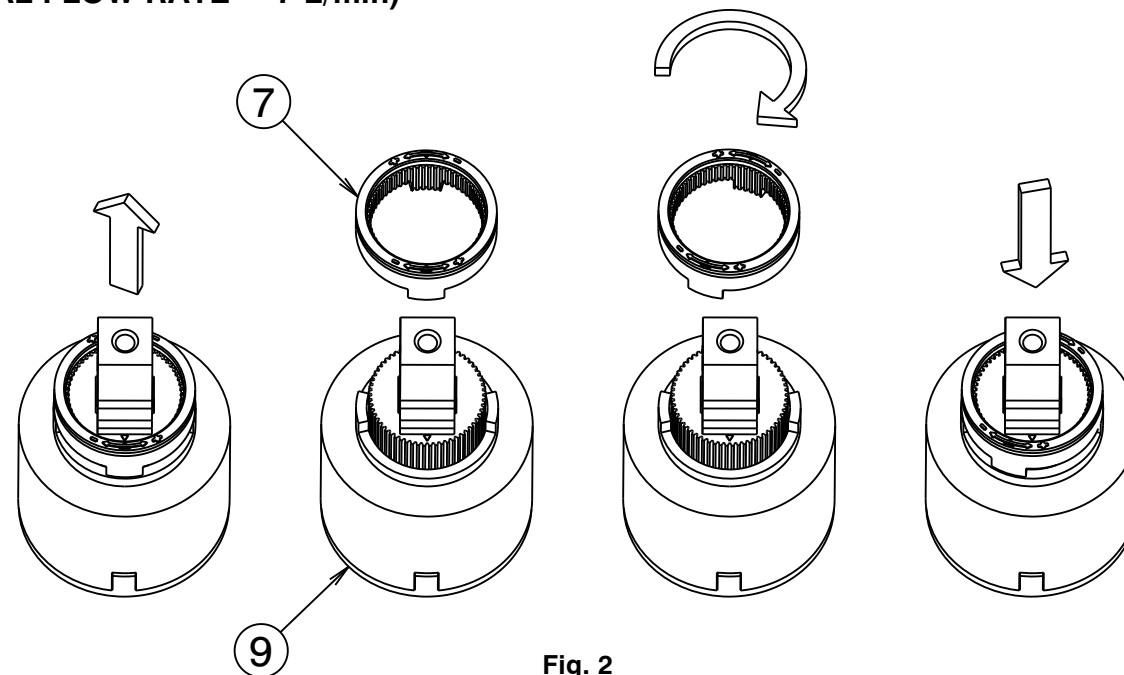

Fig. 2

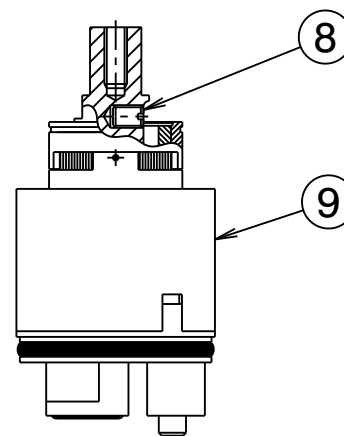

Fig. 3

Distributed by:  
Dorf Clark Industries Limited  
ABN 23 004 394 923

(SIDE 2 OF 2)  
IS1136A(08/11)